

## LMH730227/LMH730216/LMH730165 Single High Speed Op Amp Evaluation Boards (SOIC, SOT23, and SC70)

The LMH730227, LMH730216 and LMH730165 evaluation boards are designed to aid in the characterization of National Semiconductor's High Speed monolithic amplifiers.

- LMH730227 — SOIC packages
- LMH730216 — SOT23 packages
- LMH730165 — SC70 packages

Use the evaluation boards as a guide for high frequency layout and as a tool to aid in device testing and characterization.

The evaluation boards accommodate general purpose amplifiers, as well as amplifiers with the following features:

- Supply current adjustment via external Resistor
- Output disable

The evaluation board schematic is shown below. Refer to the product data sheets for recommendations for component values.

### BASIC OPERATION

These boards have identical circuit configurations and are designed to accommodate both non-inverting and inverting operation. By changing  $R_T$  or  $R_{IN}$  and  $R_{OUT}$  different input and output impedances can be matched. The SMA connectors and board traces are optimized for  $50\Omega$  operation, however other impedances can be matched as shown below.

$$\text{Inverting Gain} = R_F/R_G \quad (\text{Input Resistance} = R_T \parallel R_G)$$

$$\text{Non Inverting Gain} = 1 + R_F/(R_G + R_T) \quad (\text{Input Resistance} = R_{IN})$$

( $R_T$  may be set to zero for non inverting operation)

For current feedback operational amplifiers be careful to use appropriate values of  $R_F$ . In addition the required value of  $R_G$  will limit choices for input impedance with Inverting gains.

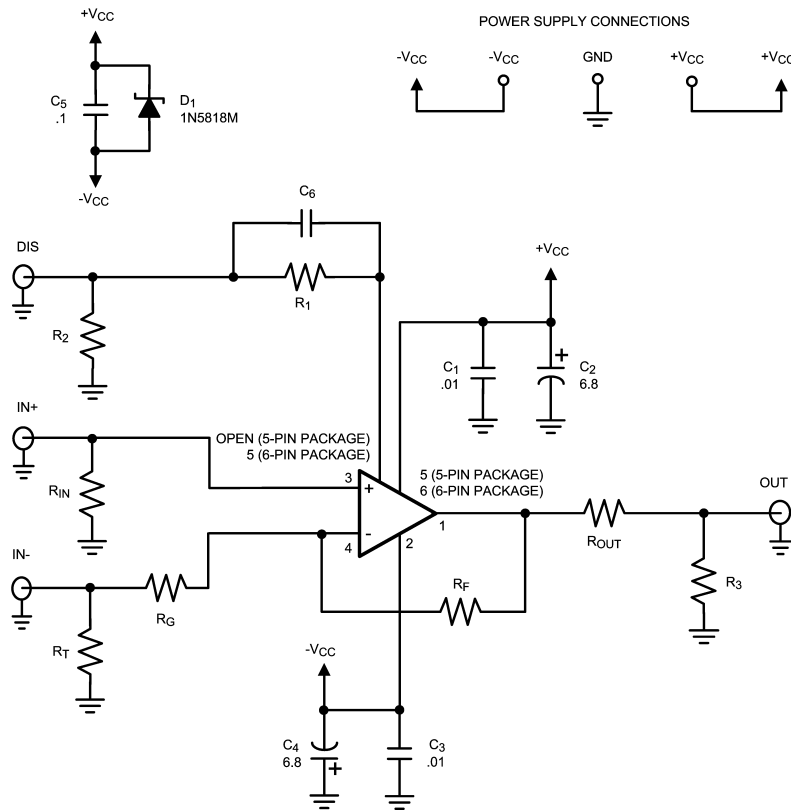
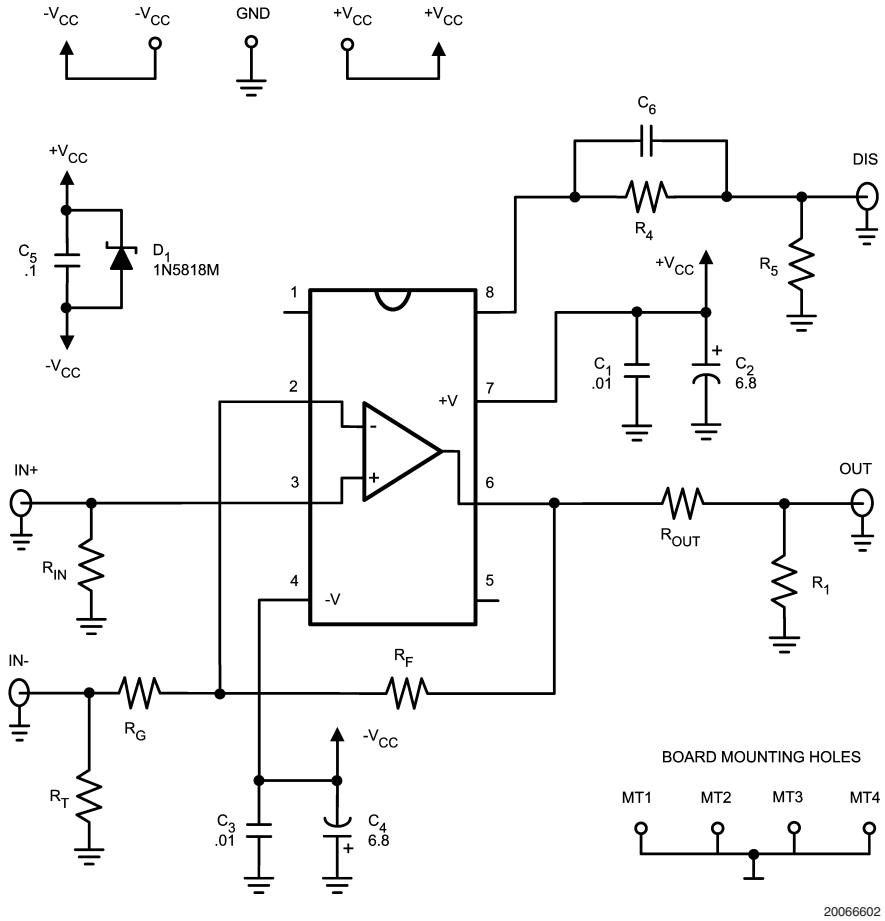

FIGURE 1. SOT and SC70 Schematic

(Continued)

**LAYOUT CONSIDERATIONS**

Printed circuit board layout and supply bypassing play major roles in determining high frequency performance. When designing your own board use these evaluation boards as a guide and follow these steps to optimize high frequency performance:



**FIGURE 2. SOIC Schematic**

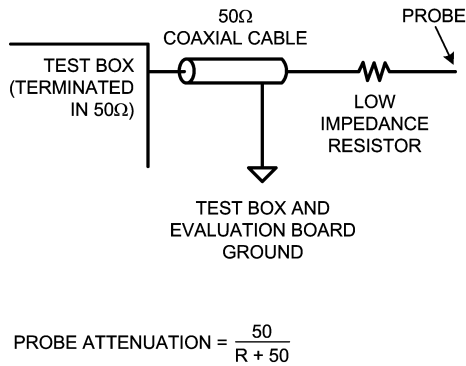

$$\text{PROBE ATTENUATION} = \frac{50}{R + 50}$$

**FIGURE 3. Probe Schematic**

(Continued)

1. Use a ground plane
2. Include large (~6.8μF) capacitors on both supplies.
3. Near the device use .01μF ceramic capacitors from both supplies to ground C<sub>1</sub>, C<sub>3</sub>.
4. Near the device use a .1μF ceramic capacitor between the supplies C<sub>5</sub>.
5. Remove the ground and power planes from under and around the part, especially the input and output pins.
6. Minimize all trace lengths
7. Use terminated transmission lines for long traces.
8. High-speed disable/enable operation requires that the enable pin be treated as a signal input.

Diode D<sub>1</sub> is to protect the device from reverse polarity supply connections and will not be necessary for most designs.

Capacitor C<sub>5</sub> is necessary for best Harmonic Distortion performance. If C<sub>5</sub> is not used increase the values of C<sub>1</sub> and C<sub>3</sub> to .1μF.

R<sub>IN</sub>, R<sub>T</sub> and R<sub>OUT</sub> are all impedance matching resistors. R<sub>IN</sub> and R<sub>OUT</sub> should be equal to the desired input/output impedance. R<sub>T</sub> || R<sub>G</sub> should equal the desired inverting input impedance. Note that with current feedback op amps, the optimum value of R<sub>F</sub> and R<sub>G</sub> is determined by the desired

gain and raising R<sub>G</sub> to obtain higher input impedance may require compromising device performance at large values of inverting gain.

The disable trace has provisions for input termination. There are also pads for series resistance and capacitance for programmable gain parts. See part datasheets for suggested values.

Sample artwork for National's Evaluation boards is included below.

The board is designed for 50Ω input and output connections into coaxial cables. For other impedances the terminating resistors can be modified to help match different impedances.

Do not use normal oscilloscope probes to test these circuits. The capacitive loading will change circuit performance drastically. Instead use low impedance resistive divider probes of 100 to 500Ω. See Figure 3 for a sample resistive probe. The Low impedance resistor should be 50-450Ω. The ground connection should be as short as possible (~1/2"). Even with careful use of these probes results should be considered preliminary until verified with controlled impedance measurements. Even the best probes will interfere with circuit operation to some degree. Also, conductors, fingers etc. near the device will change measurement results.

National Semiconductor Layer1 Silk

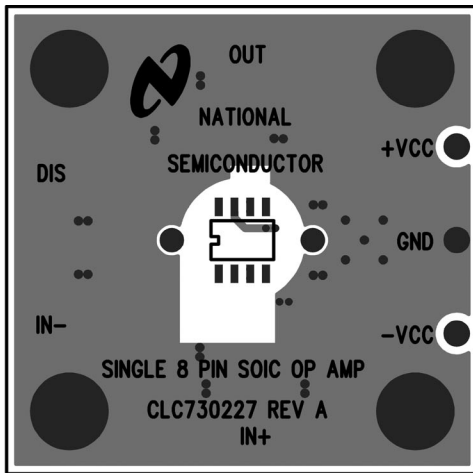

20066604

National Semiconductor Layer1 Silk

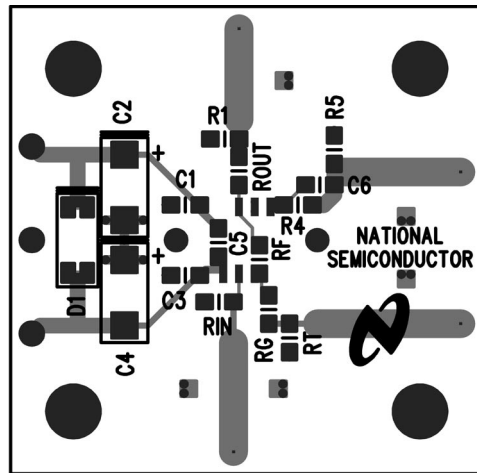

20066605

SOIC Board Layout (Actual size = 1.5" x 1.5"). The boards may be marked as CLC730227 or LMH730227

(Continued)

National Semiconductor Layer1 Silk

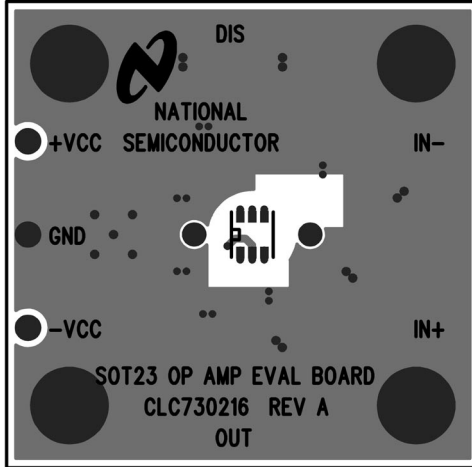

20066606

National Semiconductor Layer1 Silk

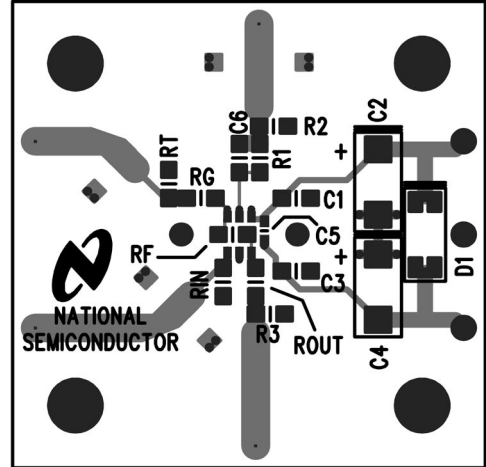

20066607

SOT Board Layout (Actual size = 1.5" x 1.5"). The boards may be marked as CLC730216 or LMH730216

National Semiconductor Layer1 Silk

NATIONAL SEMICONDUCTOR LAYER1 SILK

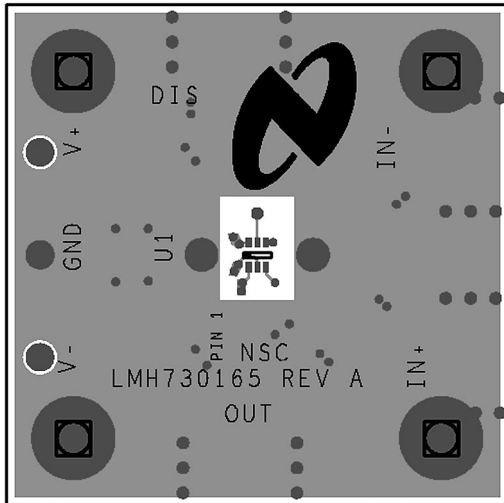

20066608

National Semiconductor Layer1 Silk

NATIONAL SEMICONDUCTOR LAYER2 SILK

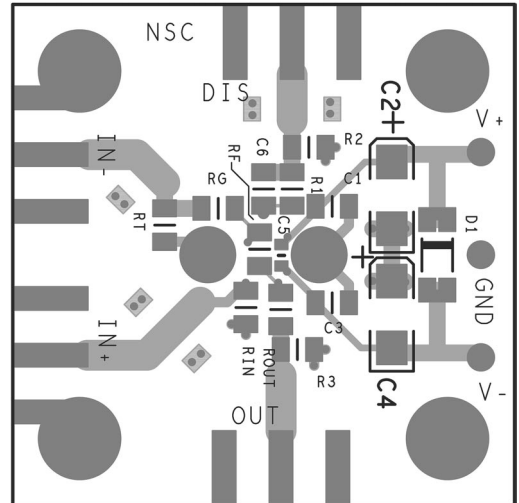

20066609

SC70 Board Layout (Actual size = 1.5" x 1.5")

## Notes

National does not assume any responsibility for use of any circuitry described, no circuit patent licenses are implied and National reserves the right at any time without notice to change said circuitry and specifications.  
 For the most current product information visit us at [www.national.com](http://www.national.com).

### LIFE SUPPORT POLICY

NATIONAL'S PRODUCTS ARE NOT AUTHORIZED FOR USE AS CRITICAL COMPONENTS IN LIFE SUPPORT DEVICES OR SYSTEMS WITHOUT THE EXPRESS WRITTEN APPROVAL OF THE PRESIDENT AND GENERAL COUNSEL OF NATIONAL SEMICONDUCTOR CORPORATION. As used herein:

- |  |   |
|--|---|
| <p>1. Life support devices or systems are devices or systems which, (a) are intended for surgical implant into the body, or (b) support or sustain life, and whose failure to perform when properly used in accordance with instructions for use provided in the labeling, can be reasonably expected to result in a significant injury to the user.</p> | <p>2. A critical component is any component of a life support device or system whose failure to perform can be reasonably expected to cause the failure of the life support device or system, or to affect its safety or effectiveness.</p> |
|--|---|

### BANNED SUBSTANCE COMPLIANCE

National Semiconductor follows the provisions of the Product Stewardship Guide for Customers (CSP-9-111C2) and Banned Substances and Materials of Interest Specification (CSP-9-111S2) for regulatory environmental compliance. Details may be found at: [www.national.com/quality/green](http://www.national.com/quality/green).

Lead free products are RoHS compliant.



**National Semiconductor**  
**Americas Customer**  
**Support Center**  
 Email: [new.feedback@nsc.com](mailto:new.feedback@nsc.com)  
 Tel: 1-800-272-9959

**National Semiconductor**  
**Europe Customer Support Center**  
 Fax: +49 (0) 180-530 85 86  
 Email: [europe.support@nsc.com](mailto:europe.support@nsc.com)  
 Deutsch Tel: +49 (0) 69 9508 6208  
 English Tel: +44 (0) 870 24 0 2171  
 Français Tel: +33 (0) 1 41 91 8790

**National Semiconductor**  
**Asia Pacific Customer**  
**Support Center**  
 Email: [ap.support@nsc.com](mailto:ap.support@nsc.com)

**National Semiconductor**  
**Japan Customer Support Center**  
 Fax: 81-3-5639-7507  
 Email: [jpn.feedback@nsc.com](mailto:jpn.feedback@nsc.com)  
 Tel: 81-3-5639-7560